

# Transient Model for Induction Machines With Stator Winding Turn Faults

Rangarajan M. Tallam, *Member, IEEE*, Thomas G. Habetler, *Senior Member, IEEE*, and  
Ronald G. Harley, *Fellow, IEEE*

**Abstract**—A transient model for an induction machine with stator winding turn faults is derived using reference frame transformation theory. A state-space representation of the dynamic equations, suitable for digital simulation is provided. Steady-state equivalent circuits are derived, from which the sequence components of the line currents can be estimated as a function of fault severity. Experimental results are provided to validate the derived model.

**Index Terms**—Fault diagnostics, induction machine transient model, negative sequence, stator winding turn fault.

## I. INTRODUCTION

A TURN FAULT in the stator winding of an induction machine causes a large circulating current to flow in the shorted turns, of the order of twice the blocked rotor current. If left undetected, turn faults can propagate, leading to phase-ground or phase-phase faults. Ground current flow results in irreversible damage to the core and the machine might have to be removed from service. Incipient detection of turn faults is essential to avoid hazardous operating conditions and reduce down time.

Modeling of induction machines with shorted turns is the first step in the development of turn-fault detection schemes [1]–[4]. Models exhibit a tradeoff between complexity and reliability. The utility of models for fault diagnosis is restricted because it is even theoretically impossible to include all nonidealities that exist in a real machine. However, models are required to obtain characteristic fault signatures and to account for the effects on them, from sources other than the faults themselves. The machine-specific models derived in [1] and [2] need motor design parameters like number of slots and stator and rotor conductor distributions. In the steady-state model proposed in [3], the shorted turns are considered as a secondary winding and ampere-turn balance is used to derive an approximate expression for the negative-sequence component of stator currents as a function of the number of shorted turns. However, the effect

of unbalanced supply voltages is ignored. In [4], magnetic coupling between stator phases is neglected to derive an approximate single-phase steady-state equivalent circuit for the phase with the shorted turns.

In this paper, a transient model for an induction machine with stator winding turn faults on a single phase is derived using reference frame transformation theory. A state-space representation of the dynamic equations suitable for digital simulation is presented. During steady state, the model reduces to sequence-component equivalent circuits. The derived model is used to prove the experimental observations made in [3] that a turn fault injects a current component into the negative-sequence equivalent circuit, independent of that due to unbalanced supply voltages. It is also proved that neither the measured negative-sequence current nor the effective negative-sequence impedance can be used as reliable indicators of the asymmetry caused by a turn fault. Experimental results, obtained with a specially wound laboratory induction motor are provided to validate the model. The limitations of the derived model are outlined and the reasons for the discrepancy between the measured and predicted current sequence components are also provided.

## II. ANALYSIS OF INDUCTION MACHINE WITH TURN FAULTS

An induction machine with stator winding turn faults on a single phase is shown in Fig. 1, where  $as_2$  represents the shorted turns and  $\mu$  denotes the fraction of shorted turns. In the derivation of the following equations, it is assumed that the leakage inductance of the shorted turns is  $\mu L_{ls}$ , where  $L_{ls}$  is the per-phase leakage inductance, and the fault impedance is resistive ( $R_f$ ).

### A. Machine Equations in $abc$ Variables

The stator and rotor equations for a symmetrical induction machine with turn faults can be expressed as [5]

$$\begin{aligned} \mathbf{v}_s &= \mathbf{R}_s \mathbf{i}_s + d\boldsymbol{\lambda}_s/dt \\ 0 &= \mathbf{R}_r \mathbf{i}_r + d\boldsymbol{\lambda}_r/dt \end{aligned} \quad (2.1)$$

where

$$\begin{aligned} \mathbf{v}_s &= [v_{as_1} \quad v_{as_2} \quad v_{bs} \quad v_{cs}]^T \\ \mathbf{i}_s &= [i_{as} \quad (i_{as} - i_f) \quad i_{bs} \quad i_{cs}]^T \\ \mathbf{i}_r &= [i_{ar} \quad i_{br} \quad i_{cr}]^T \\ \boldsymbol{\lambda}_s &= [\lambda_{as_1} \quad \lambda_{as_2} \quad \lambda_{bs} \quad \lambda_{cs}]^T \\ &= \mathbf{L}_{ss} \mathbf{i}_s + \mathbf{L}_{sr} \mathbf{i}_r \\ \boldsymbol{\lambda}_r &= \lambda_{ar} \quad \lambda_{br} \quad \lambda_{cr}]^T \\ &= \mathbf{L}_{sr}^T \mathbf{i}_s + \mathbf{L}_{rr} \mathbf{i}_r. \end{aligned}$$

Paper IPCSD 01–088, presented at the 2000 Industry Applications Society Annual Meeting, Rome, Italy, October 8–12, and approved for publication in the IEEE TRANSACTIONS ON INDUSTRY APPLICATIONS by the Electric Machines Committee of the IEEE Industry Applications Society. Manuscript submitted for review October 15, 2000 and released for publication February 25, 2002.

R. M. Tallam was with the School of Electrical and Computer Engineering, Georgia Institute of Technology, Atlanta, GA 30332-0250 USA. He is now with the Advanced Technology Laboratories, Rockwell Automation, Milwaukee, WI 53204-2410 USA (e-mail: rmtallam@ra.rockwell.com).

T. G. Habetler and R. G. Harley are with the School of Electrical and Computer Engineering, Georgia Institute of Technology, Atlanta, GA 30332-0250 USA (e-mail: thabetler@ece.gatech.edu; ron.harley@ee.gatech.edu).

Publisher Item Identifier S 0093-9994(02)04521-8.

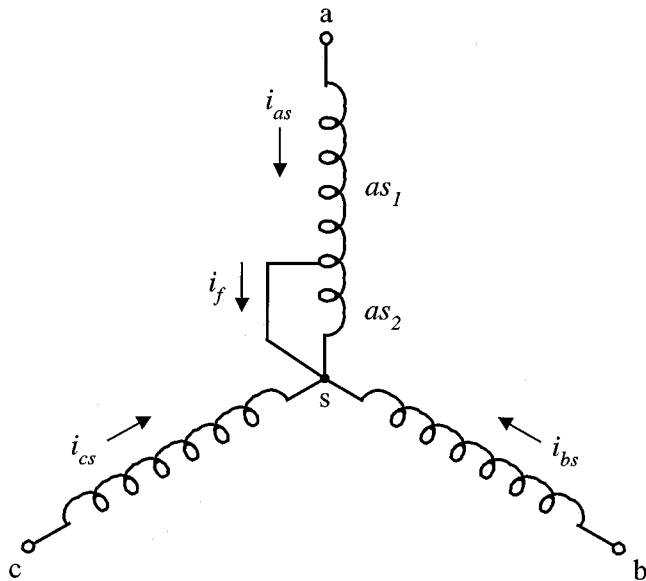

Fig. 1. Three-phase stator winding of an induction machine with turn fault on a single phase.

The resistance matrices of (2.1) are given by

$$\begin{aligned} \mathbf{R}_s &= R_s \text{diag} [1 - \mu \quad \mu \quad 0 \quad 0] \\ \mathbf{R}_r &= R_r \mathbf{I}_{3 \times 3}. \end{aligned} \quad (2.2)$$

The inductance matrices of (2.1) are given by (2.3), shown at the bottom of the page.

On adding the first two rows of (2.1) and rearranging terms, the machine equations can be expressed as

$$\begin{aligned} \mathbf{v}'_s &= R_s \mathbf{i}'_s + \frac{d\lambda'_s}{dt} + \mu \mathbf{A}_1 i_f \\ 0 &= R_r \mathbf{i}_r + \frac{d\lambda_r}{dt} \end{aligned} \quad (2.4)$$

where

$$\begin{aligned} \mathbf{v}'_s &= [v_{as} \quad v_{bs} \quad v_{cs}]^T \\ \mathbf{i}'_s &= [i_{as} \quad i_{bs} \quad i_{cs}]^T \\ \lambda'_s &= [(\lambda_{as1} + \lambda_{as2}) \quad \lambda_{bs} \quad \lambda_{cs}]^T \\ &= \mathbf{L}'_{ss} \mathbf{i}'_s + \mathbf{L}'_{sr} \mathbf{i}_r + \mu \mathbf{A}_2 i_f \\ \lambda_r &= \mathbf{L}'_{srT} \mathbf{i}'_s + \mathbf{L}_{rr} \mathbf{i}_r + \mu \mathbf{A}_3 i_f \\ \mathbf{A}_1 &= -[R_s \quad 0 \quad 0]^T \\ \mathbf{A}_2 &= [-(L_{ls} + L_{ms}) \quad L_{ms}/2 \quad L_{ms}/2]^T \\ \mathbf{A}_3 &= -L_{ms} [\cos \theta_r \quad \cos(\theta_r + 2\pi/3) \quad \cos(\theta_r - 2\pi/3)]^T. \end{aligned}$$

The modified inductance matrices are given by

$$\begin{aligned} \mathbf{L}'_{ss} &= \begin{bmatrix} L_{ls} + L_{ms} & -L_{ms}/2 & -L_{ms}/2 \\ -L_{ms}/2 & L_{ls} + L_{ms} & -L_{ms}/2 \\ -L_{ms}/2 & -L_{ms}/2 & L_{ls} + L_{ms} \end{bmatrix} \\ \mathbf{L}'_{sr} &= L_{ms} \begin{bmatrix} \cos \theta_r & \cos(\theta_r + 2\pi/3) & \cos(\theta_r - 2\pi/3) \\ \cos(\theta_r - 2\pi/3) & \cos \theta_r & \cos(\theta_r + 2\pi/3) \\ \cos(\theta_r + 2\pi/3) & \cos(\theta_r - 2\pi/3) & \cos \theta_r \end{bmatrix}. \end{aligned} \quad (2.5)$$

For the shorted turns ( $as_2$ ), the voltage and flux linkage equations are

$$\begin{aligned} v_{as_2} &= \mu R_s (i_{as} - i_f) + d\lambda_{as_2}/dt = R_f i_f \\ \lambda_{as_2} &= -\mu \mathbf{A}_2^T \mathbf{i}'_s - \mu \mathbf{A}_3^T \mathbf{i}_r - \mu (L_{ls} + \mu L_{ms}) i_f. \end{aligned} \quad (2.6)$$

$$\begin{aligned} \mathbf{L}_{ss} &= L_{ls} \text{diag} [1 - \mu \quad \mu \quad 0 \quad 0] + L_{ms} \begin{bmatrix} (1 - \mu)^2 & \mu(1 - \mu) & -\frac{1 - \mu}{2} & -\frac{1 - \mu}{2} \\ \mu(1 - \mu) & \mu^2 & -\frac{\mu}{2} & -\frac{\mu}{2} \\ -\frac{1 - \mu}{2} & -\frac{\mu}{2} & 1 & -1/2 \\ -\frac{1 - \mu}{2} & -\frac{\mu}{2} & -1/2 & 1 \end{bmatrix} \\ \mathbf{L}_{sr} &= L_{ms} \begin{bmatrix} (1 - \mu) \cos \theta_r & (1 - \mu) \cos(\theta_r + 2\pi/3) & (1 - \mu) \cos(\theta_r - 2\pi/3) \\ \mu \cos \theta_r & \mu \cos(\theta_r + 2\pi/3) & \mu \cos(\theta_r - 2\pi/3) \\ \cos(\theta_r - 2\pi/3) & \cos \theta_r & \cos(\theta_r + 2\pi/3) \\ \cos(\theta_r + 2\pi/3) & \cos(\theta_r - 2\pi/3) & \cos \theta_r \end{bmatrix} \\ \mathbf{L}_{rr} &= \begin{bmatrix} L_{lr} + L_{ms} & -L_{ms}/2 & -L_{ms}/2 \\ -L_{ms}/2 & L_{lr} + L_{ms} & -L_{ms}/2 \\ -L_{ms}/2 & -L_{ms}/2 & L_{lr} + L_{ms} \end{bmatrix} \end{aligned} \quad (2.3)$$

The electromagnetic torque can be expressed in machine  $abc$  variables as

$$T = \frac{P}{2} \mathbf{i}_s^T \frac{\partial \mathbf{L}_{sr}}{\partial \theta_r} \mathbf{i}_r. \quad (2.7)$$

On rearranging terms in (2.7), the electromagnetic torque can also be expressed as

$$T = \frac{P}{2} \mathbf{i}_s^T \frac{\partial L'_{sr}}{\partial \theta_r} \mathbf{i}_r - \mu \frac{P}{2} L_{ms} i_f \left\{ \frac{3}{2} i_{ar} \sin \theta_r + \frac{\sqrt{3}}{2} (i_{br} - i_{cr}) \cos \theta_r \right\}. \quad (2.8)$$

The first term in (2.8) is the standard expression for torque developed by a symmetrical induction machine. The second term, which is the effect of the turn fault, results in a double-line-frequency pulsation in the torque and speed.

### B. Reference Frame Transformation

On transforming (2.4) and (2.6) to the stationary reference frame, the machine equations can be expressed in complex  $dq$  variables as follows:

$$\begin{aligned} v_{qds}^s &= R_s i_{qds}^s + p \lambda_{qds}^s - \frac{2}{3} \mu R_s i_f \\ v_{os}^s &= -\frac{1}{3} \mu R_s i_f + p \lambda_{os}^s \\ 0 &= R_r i_{qdr}^s + (p - j\omega_r) \lambda_{qdr}^s \\ \lambda_{qds}^s &= L_s i_{qds}^s + L_m i_{qdr}^s - \frac{2}{3} \mu L_s i_f \\ \lambda_{os}^s &= -\frac{1}{3} \mu L_s i_f \\ \lambda_{qdr}^s &= L_r i_{qdr}^s + L_m i_{qds}^s - \frac{2}{3} \mu L_m i_f \end{aligned} \quad (2.9)$$

where  $p$  represents the operator  $d/dt$ , and

$$\begin{aligned} f_{qdx}^s &= f_{qx}^s - j f_{dx}^s \\ L_s &= L_{ls} + \frac{3}{2} L_{ms} \\ L_r &= L_{lr} + \frac{3}{2} L_{ms} \\ \omega_r &= p \theta_r. \end{aligned}$$

The voltage equations for the faulted turns (2.6) can be expressed in  $dq$  variables as follows:

$$\begin{aligned} v_{as2} &= R_f i_f = \mu R_s (i_{qs}^s + i_{os} - i_f) + p \lambda_{as2} \\ \lambda_{as2} &= \mu L_s (i_{qs}^s + i_{os} - i_f) \\ &\quad + \mu L_m \left( i_{qs}^s + i_{qr}^s - \frac{2}{3} \mu i_f \right). \end{aligned} \quad (2.10)$$

The electromagnetic torque (2.8) can be expressed in  $dq$  variables as

$$T = \frac{3}{2} \frac{P}{2} L_m (i_{qs}^s i_{dr}^s - i_{ds}^s i_{qr}^s) - \frac{P}{2} \mu L_m i_f i_{qr}^s. \quad (2.11)$$

The second term in (2.11), which represents the effect of a turn fault, produces a double-line-frequency torque pulsation. The electrical dynamics of an induction machine with stator winding turn faults is completely described in  $dq$  variables by (2.9)–(2.11).

### III. STATE-SPACE MODEL FOR DIGITAL SIMULATION

The dynamic equations of the induction machine must be expressed in state-space form for the purpose of digital simulation. Let  $\mathbf{x} = [\lambda_{qs}^s \lambda_{ds}^s \lambda_{qr}^s \lambda_{dr}^s \lambda_{as2}]^T$  be the state vector. The flux linkages can be expressed in terms of the currents as

$$\mathbf{x} = \mathbf{M} [i_{qs}^s \ i_{ds}^s \ i_{qr}^s \ i_{dr}^s \ i_f]^T \quad (3.1)$$

where

$$\mathbf{M} = \begin{bmatrix} L_s & 0 & L_m & 0 & -\frac{2}{3} \mu L_s \\ 0 & L_s & 0 & L_m & 0 \\ L_m & 0 & L_r & 0 & -\frac{2}{3} \mu L_m \\ 0 & L_m & 0 & L_r & 0 \\ \mu L_s & 0 & \mu L_m & 0 & -\mu \left( L_{ls} + \frac{2}{3} \mu L_m \right) \end{bmatrix}.$$

If  $\mu \neq 0$ , then the matrix  $\mathbf{M}$  is invertible. Setting  $\mathbf{N} = \mathbf{M}^{-1}$ , the machine equations can be expressed in state-space form as

$$\begin{aligned} \frac{d\mathbf{x}}{dt} &= \mathbf{A}\mathbf{x} + \begin{bmatrix} 1 & 0 & 0 & 0 & 0 \\ 0 & 1 & 0 & 0 & 0 \end{bmatrix}^T \begin{bmatrix} v_{qs}^s \\ v_{ds}^s \end{bmatrix} \\ \mathbf{A} &= \begin{bmatrix} R_s \mathbf{N}_1 + \frac{2}{3} \mu R_s \mathbf{N}_5 \\ R_s \mathbf{N}_2 \\ R_r \mathbf{N}_3 + \omega_r [0 \ 0 \ 0 \ 1 \ 0] \\ R_r \mathbf{N}_4 - \omega_r [0 \ 0 \ 1 \ 0 \ 0] \\ \mu R_s \mathbf{N}_1 + \mu (R_s + R_f) \mathbf{N}_5 \end{bmatrix} \end{aligned} \quad (3.2)$$

where  $\mathbf{N}_i$  denotes the  $i$ th row of matrix  $\mathbf{N}$ .

The zero-sequence component of stator voltages is given by

$$v_{os}^s = -\frac{1}{3} \mu R_s \mathbf{N}_5 \mathbf{x} - \frac{1}{3} \mu L_{ls} \mathbf{N}_5 \frac{d\mathbf{x}}{dt}. \quad (3.3)$$

For an induction machine without any asymmetry, such as turn faults, the zero-sequence component of stator voltages is zero, regardless of the unbalance in the supply voltages. A stator winding turn-fault detection scheme based on monitoring the zero-sequence voltage component has been proposed in [6] for wye-connected induction machines. The method requires a signal-level connection to the neutral point of the stator winding.

### IV. ANALYSIS OF STEADY-STATE OPERATION

In general, turn-fault detection schemes are based on monitoring the negative-sequence component of line currents, to detect an asymmetry caused by the fault. By performing a steady-state analysis of (2.9) and (2.10), an estimate of the sequence components of line currents can be obtained, for different load levels and fault conditions.

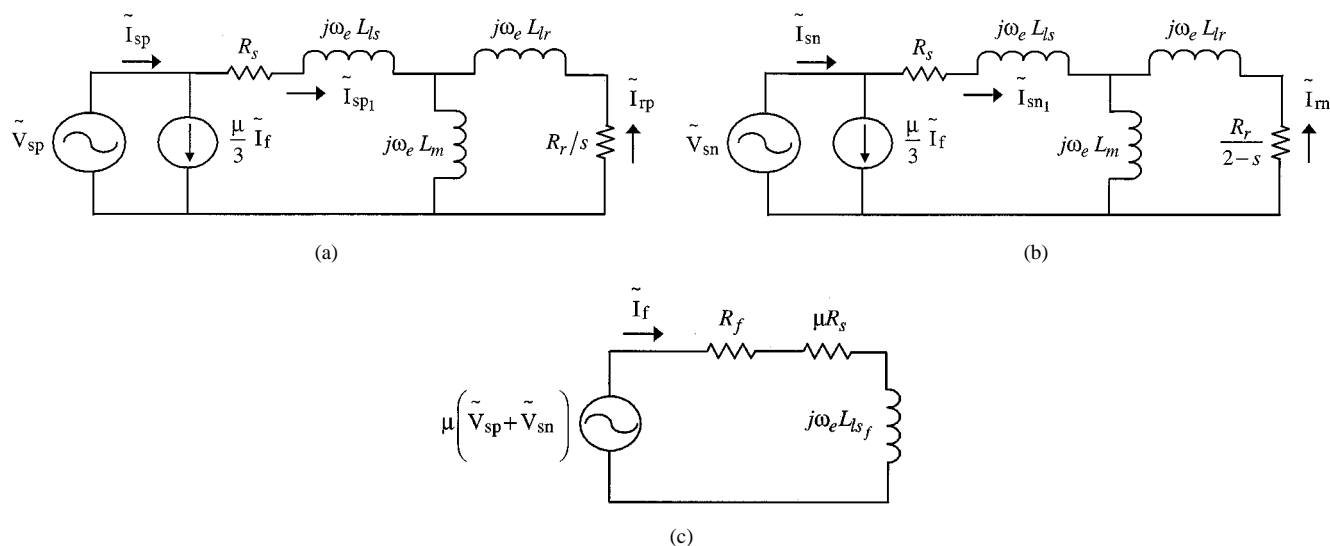

Fig. 2. Steady-state equivalent circuits of an induction machine with stator winding turn fault. (a) Positive-sequence line current component. (b) Negative-sequence line current component. (c) Fault current.

### A. Phasor Equations

In sinusoidal steady state, the complex variable  $f_{qds}^s$  can be expressed in terms of the positive- ( $F_p$ ) and negative-sequence ( $F_n$ ) component phasors as [7]

$$f_{qds}^s = \sqrt{2} \left( \tilde{F}_p e^{j\omega_e t} + \tilde{F}_n^* e^{-j\omega_e t} \right). \quad (4.1)$$

On applying (4.1) to (2.9), the steady-state stator and rotor equations for an induction machine with turn faults are

$$\begin{aligned} \tilde{V}_{sp} &= (R_s + j\omega_e L_s) \left( \tilde{I}_{sp} - \frac{1}{3} \mu \tilde{I}_f \right) + j\omega_e L_m \tilde{I}_{rp} \\ \tilde{V}_{sn} &= (R_s + j\omega_e L_s) \left( \tilde{I}_{sn} - \frac{1}{3} \mu \tilde{I}_f \right) + j\omega_e L_m \tilde{I}_{rn} \\ 0 &= (R_r/s + j\omega_e L_r) \tilde{I}_{rp} + j\omega_e L_m \left( \tilde{I}_{sp} - \frac{1}{3} \mu \tilde{I}_f \right) \\ 0 &= \left( \frac{R_r}{2-s} + j\omega_e L_r \right) \tilde{I}_{rn} + j\omega_e L_m \left( \tilde{I}_{sn} - \frac{1}{3} \mu \tilde{I}_f \right) \end{aligned} \quad (4.2)$$

where  $\tilde{I}_{sp}$ ,  $\tilde{I}_{sn}$ ,  $\tilde{I}_{rp}$ , and  $\tilde{I}_{rn}$  are the positive- and negative-sequence component phasors of the stator and rotor currents,  $\tilde{I}_f$  is the phasor of the fault current, and  $s$  is the slip. The fault current phasor is given in terms of the stator voltage sequence components by

$$\mu(\tilde{V}_{sp} + \tilde{V}_{sn}) = \mu(1 - 2\mu/3)(R_s + j\omega_e L_s) \tilde{I}_f + R_f \tilde{I}_f. \quad (4.3)$$

### B. Steady-State Equivalent Circuits

Equations (4.2) and (4.3) can also be elegantly expressed in terms of sequence-component equivalent circuits for an induction machine with stator winding turn faults, as shown in Fig. 2. In obtaining Fig. 2(c), it is assumed that  $\mu \ll 1$ . An admittance

matrix relating the sequence components of machine voltages and currents can be obtained from (4.2) and (4.3) as

$$\begin{bmatrix} \tilde{I}_{sp} \\ \tilde{I}_{sn} \end{bmatrix} = \begin{bmatrix} Y_{pp} & Y_{pn} \\ Y_{np} & Y_{nn} \end{bmatrix} \begin{bmatrix} \tilde{V}_{sp} \\ \tilde{V}_{sn} \end{bmatrix} \quad (4.4)$$

where

$$\begin{aligned} Y_{pp} &= Y_p + Y_{pn} \\ Y_{nn} &= Y_n + Y_{np} \\ Y_{pn} = Y_{np} &= \frac{\mu^2/3}{R_f + \mu(R_s + j\omega_e L_s)}. \end{aligned}$$

$Y_p$  and  $Y_n$  are the positive- and negative-sequence admittances of an ideal symmetrical induction machine and are given by (see Fig. 2)

$$Y_p = \frac{\tilde{I}_{sp1}}{\tilde{V}_{sp}}, \quad Y_n = \frac{\tilde{I}_{sn1}}{\tilde{V}_{sn}}. \quad (4.5)$$

For a machine with no stator asymmetry, the terms  $Y_{np}$  and  $Y_{pn}$  are identically zero. Hence, it is also possible to detect a turn fault by monitoring the off-diagonal terms of the admittance matrix.

From the equivalent circuits of Fig. 2, it is clear that the effect of a turn fault is to inject a component of current into the positive- and negative-sequence equivalent circuits of a symmetrical machine. This is in agreement with the experimental observation made in [4]. The magnitude of the injected negative-sequence current as predicted by Fig. 2 is identical to the estimate obtained in [3]. It is clear that the measured negative-sequence current component is the phasor sum of the contributions due to the turn fault and the unbalanced supply voltages

$$\tilde{I}_{sn} = \frac{1}{3} \mu \tilde{I}_f + Y_n \tilde{V}_{sn}. \quad (4.6)$$

Since the negative-sequence voltage can have an arbitrary phase with respect to the positive-sequence voltage, the measured negative-sequence current could reduce when a turn fault occurs.

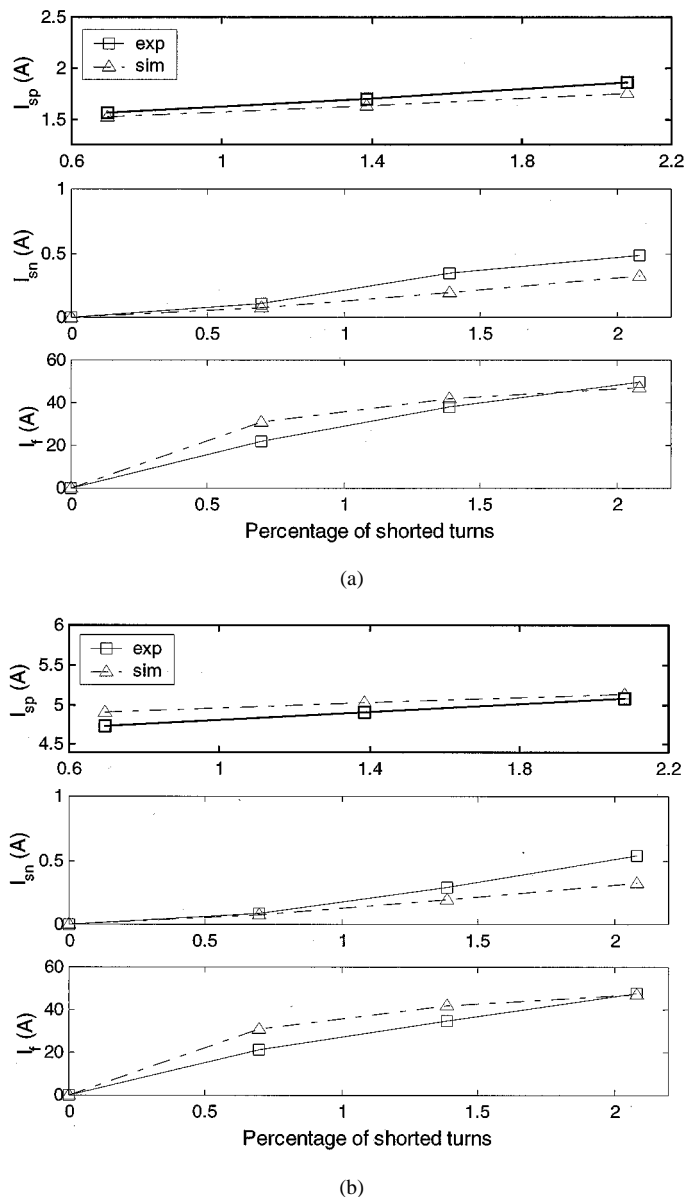

Fig. 3. Experimental and simulation results for the sequence components of line currents and the fault current. (a) No load. (b) Rated slip.

Hence, neither the measured negative-sequence current nor the effective negative-sequence impedance is a reliable indicator of a turn fault.

## V. EXPERIMENTAL RESULTS

A specially rewound three-phase 400-V 10-hp 1750-r/min induction machine was used for testing. The machine, with 144 series turns per phase, had taps in the stator winding to create turn faults externally. The machine was operated at reduced voltage (230 V) to avoid damage to the stator windings. Experimental and simulation results are shown in Fig. 3 for a bolted fault and balanced supply voltages.

Any induction machine exhibits a certain degree of inherent asymmetry. It was observed that the stator currents of the test machine contained a negative-sequence component, without a

fault applied, even for balanced voltages. Further, this asymmetry was also dependent on the load (slip). In order to perform a meaningful comparison between experimental and simulation results, the measured negative-sequence component of currents was compensated for the effects of unbalanced supply voltages and machine nonidealities. From (4.4), the negative-sequence component of currents can be expressed as

$$\tilde{I}_{sn} = k_1 \tilde{V}_{sp} + k_2 \tilde{V}_{sn} \quad (5.1)$$

where  $k_1$  and  $k_2$  are load-dependent complex numbers. Six sets of data were obtained, one set for each of six different load levels, with no turn fault applied, and the complex constants were determined using least-squared-error estimation. Then, with a turn fault applied, the negative-sequence current due to unbalanced voltages and inherent asymmetry effects, as estimated by (5.1), was subtracted to obtain the fault signature.

From the results shown in Fig. 3, it is clear that the experimental and simulation results for the sequence components of line currents and the fault current follow the same trend. However, the predicted magnitudes differ slightly from the experimental observations. This is largely due to the error in the estimate of the leakage reactance of the faulted turns, as noted in [1]. The leakage reactance depends on the physical location of the faulted turns in the stator winding.

## VI. CONCLUSIONS

A transient model for an induction machine with stator winding turn faults on a single phase has been derived using reference frame transformation theory. The dynamic equations were presented in state-space form, which is suitable for digital simulation. Steady-state equivalent circuits have also been derived, to estimate the sequence-components of line currents as a function of fault severity. Experimental results, with correction applied for the effects of inherent asymmetry, have been shown to exhibit the same trend as predicted by the model. This model is expected to find applications in the development of stator winding turn-fault detection schemes for induction machines.

## REFERENCES

- [1] S. Williamson and P. Mirzoian, "Analysis of cage induction motor with stator winding turn faults," *IEEE Trans. Power App. Syst.*, vol. 104, pp. 1838–1842, July 1985.
- [2] X. Luo, Y. Liao, H. A. Toliyat, A. El-Antably, and T. A. Lipo, "Multiple coupled circuit modeling of induction machines," *IEEE Trans. Ind. Appl.*, vol. 31, pp. 311–317, Mar./Apr. 1995.
- [3] F. Filippetti, G. Franceschini, C. Tassoni, A. Ometto, and S. Meo, "A simplified model of induction machine with stator shorted turns oriented to diagnostics," in *Proc. IECM'96*, vol. 3, 1996, pp. 410–413.
- [4] G. B. Kliman, W. J. Premerlani, R. A. Koegl, and D. Hoeweler, "A new approach to on-line turn fault detection in ac motors," in *Conf. Rec. IEEE-IAS Annu. Meeting*, vol. 1, 1996, pp. 687–693.
- [5] P. C. Krause, O. Wasynczuk, and S. D. Sudhoff, *Analysis of Electric Machinery*. New York: IEEE Press, 1996.
- [6] M. A. Cash, T. G. Habetler, and G. B. Kliman, "Insulation failure prediction in induction machines using line-neutral voltages," in *Conf. Rec. IEEE-IAS Annu. Meeting*, vol. 1, 1997, pp. 208–212.
- [7] D. W. Novotny and T. A. Lipo, *Vector Control and Dynamics of AC Drives*. New York: Oxford Univ. Press, 1996.



**Rangarajan M. Tallam** (S'97–M'01) received the B.Tech. degree in electrical engineering from Indian Institute of Technology, Madras, India, and the M.S.E.E. and Ph.D. degrees from Georgia Institute of Technology, Atlanta, in 1997, 1999, and 2001, respectively.

He is currently a Research Engineer in the Advanced Technology Laboratories, Rockwell Automation, Milwaukee, WI. In 1998, he was an Engineering Intern with Lutron Electronics Company Inc., Coopersburg, PA, where he worked on the design of reduced-switch topologies for electronic fluorescent dimming ballasts. His research interests are in modeling, control, and condition monitoring of electric machines, and power electronics.

Dr. Tallam served as the Treasurer and President of the Georgia Institute of Technology Student Chapter of the IEEE Power Engineering Society from 1999 to 2001. He is a member of the IEEE Industry Applications Society. He received the Dr. Ing. Dieter Kind Award for the best undergraduate project in electric power engineering and was a recipient of the National Talent Scholarship Award from the Government of India.



**Thomas G. Habetler** (S'82–M'83–SM'92) received the B.S.E.E. and M.S. degrees in electrical engineering from Marquette University, Milwaukee, WI, and the Ph.D. degree from the University of Wisconsin, Madison, in 1981, 1984, and 1989, respectively.

From 1983 to 1985, he was a Project Engineer with the Electro-Motive Division, General Motors, where he was involved in the design of switching power supplies and voltage regulators for locomotive applications. He is currently a Professor of Electrical Engineering at Georgia Institute of Technology, Atlanta. His research interests are in switching converter technology and electric machine protection and drives.

Dr. Habetler was corecipient of the 1989 First Prize Paper Award and 1991 Second Prize Paper Award of the Industrial Drives Committee, and 1994 Second Prize Paper Award of the Electric Machines Committee of the IEEE Industry Applications Society (IAS). He serves as the President of the IEEE Power Electronics Society, and Chair of the Industrial Power Converter Committee of the IAS.



**Ronald G. Harley** (M'77–SM'86–F'92) received the M.Sc.Eng. degree from the University of Pretoria, Pretoria, South Africa, and the Ph.D. degree from Imperial College, London, U.K., in 1965 and 1969, respectively.

In 1971, he was appointed Professor of Electric Machines and Control at the University at Natal, Durban, South Africa. He was a Visiting Professor at Iowa State University, Ames, in 1977, Clemson University, Clemson, SC, in 1987, and Georgia Institute of Technology, Atlanta in 1994. He is currently the Duke Power Company Distinguished Professor of Electrical Engineering, Georgia Institute of Technology, Atlanta. His areas of research include power system dynamics, electrical machines, power electronics, and control of ac variable-speed drives.

Dr. Harley is a member of the IEEE Power Engineering and IEEE Industry Applications Societies. He is also a Fellow of the the Institution of Electrical Engineers, U.K., and South Africa Institute of Engineers.